

HIVACON

vacuum technology

Vacuum conveying systems are commonly used for material transportation in the food industry.

- **Material handling capacity up to 4000 kg / h per system with 10 pcs of suction points.**
- **Guarantees the performance of material handling from edible by-products in to waste categories.**
- **Available for CIP washing integration.**
- **100% automated**
- **Custom tailored turn-key solutions in green field and brown field projects**
- **Direct impact for smooth flow of the whole process line.**
- **An increase in hygiene and reduction of cross contamination.**
- **Improving the safety and efficiency of resources.**

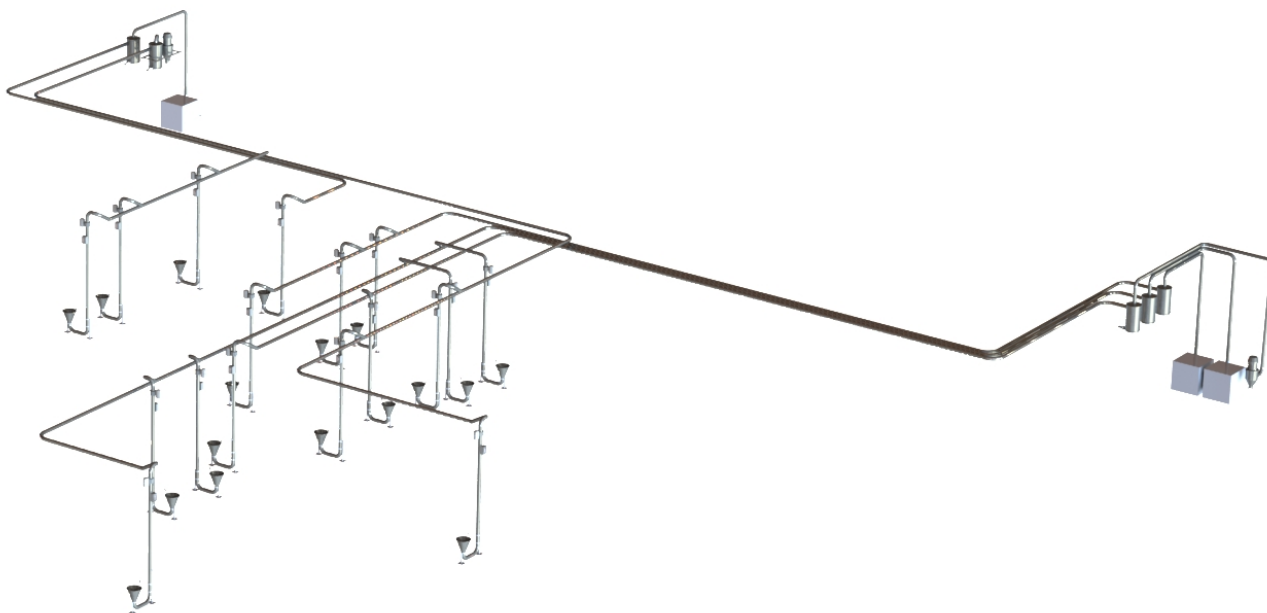

HIVACON
Systems
www.hivacon.fi

Hivacon systems Oy is automation system supplier and management service provider

Hivacon Systems Oy, Haukantie 6, 04320 Tuusula, Finland

Email: jouni.kahkonen@hivacon.fi, Phone/ WhatsApp: +358406613231

VAT number 2877142-1

www.hivacon.fi